

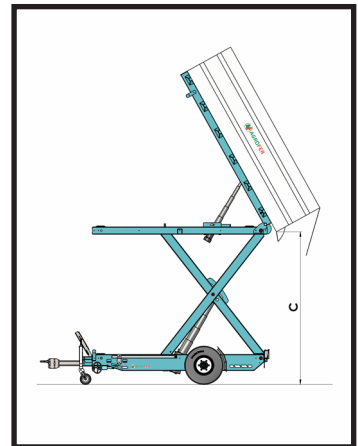

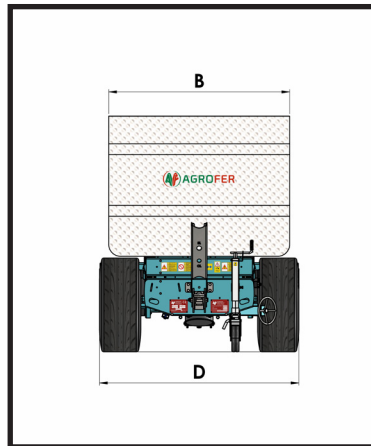

# TRAILER DDF / SP

- Trailer for harvesting and transporting grapes
- Sectioned tubular construction
- Hydraulic lifting scissor structure with hydraulic cylinder
- TRACTOR OIL OPERATION
- With rear drain, container lift with hydraulic cylinder
- TRACTOR OIL OPERATION
- Fix drawbar - E3 eyelet
- Rigid axle with mechanical brake 300x60
- Movable support foot
- Light kit
- Front fluid guards
- Watertight tank in AISI 304 STAINLESS STEEL
- Painted iron frame under the container
- Opening rear door with 2 double effect cylinders
- TRACTOR OIL OPERATION
- Tractor N 3 pairs of double acting hydraulic jacks
- TRACTOR OIL REQUIRED 60lt

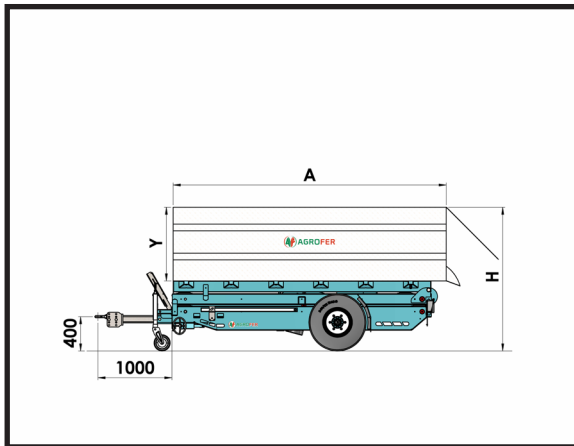

MOD.	A mm	B mm	C mm	D mm	Y mm	H mm		 Kg.	 M3	€
DDF / SP.35x15	3500	1500	3000	1600	900	1800	340/55-16 o 11/080 15.3	2000	4.5	

## BRAKING COST FOR 6000 Kg

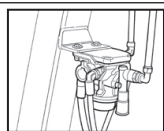
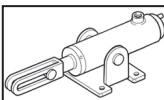
	PNEUMATIC	
	HYDRAULIC WITH PEDAL	