

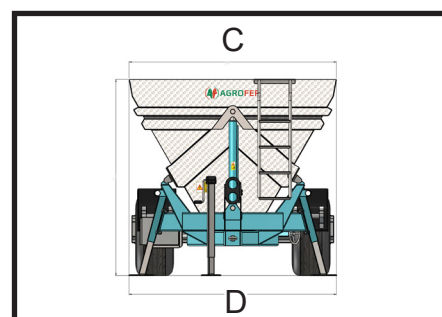

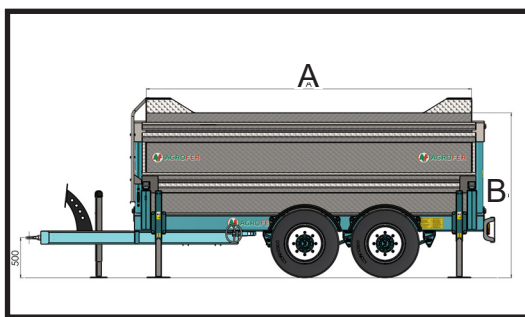

# CARRO BL TANDEM INOX

- Carro con scarico laterale BL Dx Sx
- Telaio in tubolare sezionato
- Ribaltamento bilaterale lato DX+SX con cilindri a doppio effetto funzionamento olio trattore
- Timone fisso con occhione F2
- Assale a bilanciare Tandem, CANTILEVER CON BALESTRE
- Assale posteriore sterzante con bloccaggio idraulico funzionamento olio trattore
- Piedino anteriore di appoggio manuale
- Ruote usate e rigenerate
- Kit fanali
- Trattore N3 prese idrauliche a doppio effetto OLIO TRATTORE NECESSARIO 50lt
- Vasca a tenuta stagna in acciaio inox con lamiera fiorettata aisi 304

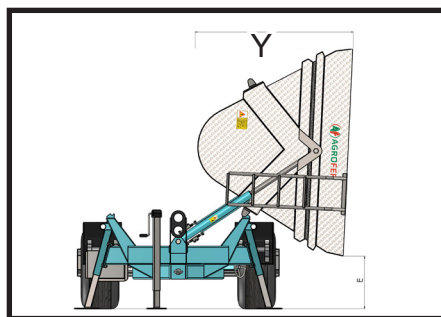
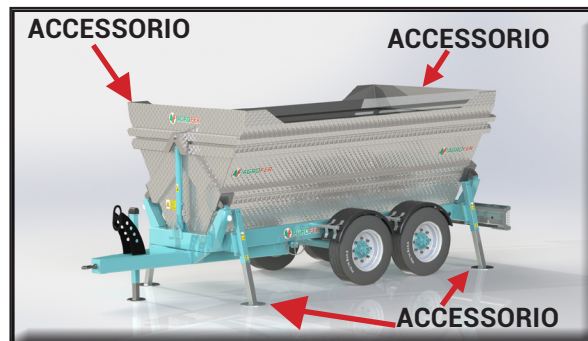

| MOD.        | A mm | B mm | C mm | D mm | Y mm |  | <br>Kg. | <br>m <sup>3</sup> | CERTIFICATO<br>OMOLOGAZIONE<br>ITALIANA<br>12.000/14.000kg |
|-------------|------|------|------|------|------|---|--|--|--|
| BL120 TA 40 | 4000 | 2300 | 2500 | 2500 | 1200 | 305/70 R 19.5<br>385/55 R 19.5  | 2700   | 8  |  |
| BL140 TA 50 | 5000 | 2300 | 2500 | 2500 | 1200 | 305/70 R 19.5<br>385/55 R 19.5  | 3200   | 10   |  |

## COSTI SISTEMA FRENANTE PER OMOLOGAZIONE STRADALE 12000-14000-18000Kg

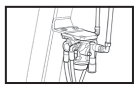
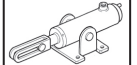
|   |                    |  |
|---|--------------------|--|
|  | PNEUMATICO         |  |
|  | IDRAULICO A PEDALE |  |

|   |
|---|
| KIT OMOLOGAZIONE<br>STRADALE ITALIANA<br>IN.M.R. kg 18000 |
|   |