

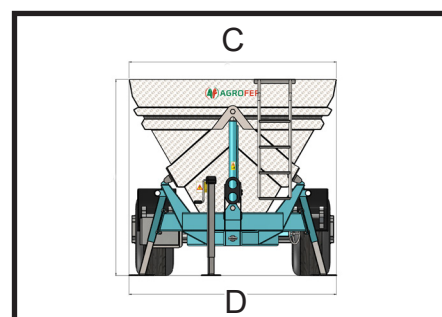

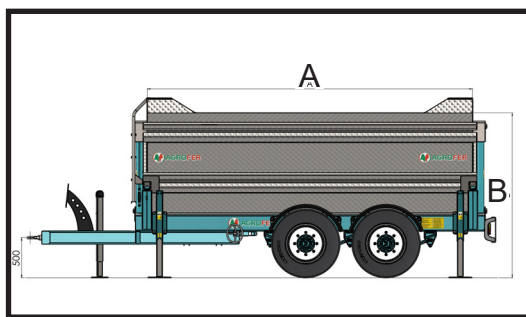

TANDEM ANHÄNGER BL INOX

- Trailer with side discharge BL Right-Left
 - Sectioned tubular frame
 - Bilateral tipping on the right+left side with double effect cylinders tractor oil operation
 - Fixed drawbar with F2 eyelet
 - Tandem axle, CANTILEVER WITH SPRINGS
 - Steering rear axle with hydraulic locking tractor oil operation
 - Front manual support foot
 - Used and remanufactured wheels
 - Light kit
 - Tractor N3 double-acting hydraulic jacks
- REQUIRED TRACTOR OIL 50lt
- Watertight stainless-steel tank with flowered sheet metal aisi 304

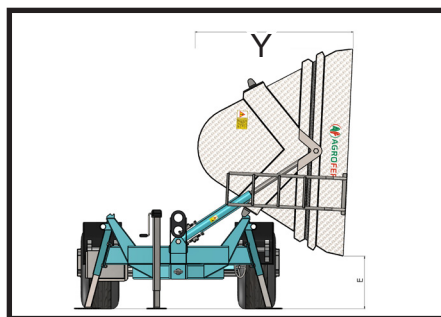
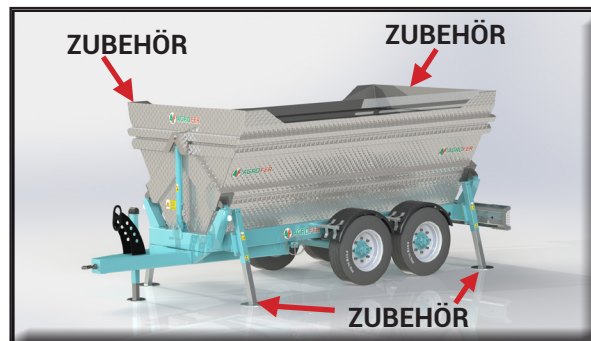

MOD.	A mm	B mm	C mm	D mm	Y mm		 Kg.	 m ³	€
BL120 TA 40	4000	2300	2500	2500	1200	305/70 R 19.5 385/55 R 19.5	2700	8	
BL140 TA 50	5000	2300	2500	2500	1200	305/70 R 19.5 385/55 R 19.5	3200	10	

BREMS ANLAGE KOST für 12000-14000Kg

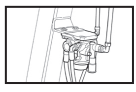
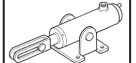
	PNEUMATISCH	
	HYDRAULISCH MIT PEDAL	

ZUBEHÖR AUF SEITE pag. 86