

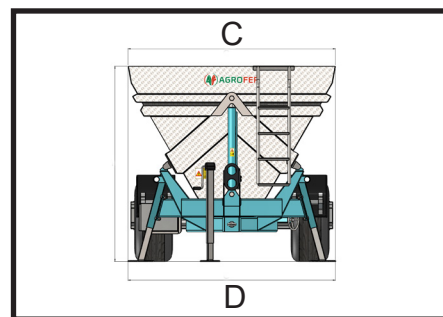

TRAILER BL SINGLE-AXLE INOX

- Trailer with side discharge BL Right-Left
 - Sectioned tubular frame
 - Bilateral tipping on the right+left side with double effect cylinders tractor oil operation
 - Fixed drawbar with E3 eyelet
 - 6-hole rigid axle with mechanical brake
 - Front manual support foot
 - Light kit
 - Tractor N1 double-acting hydraulic outlet
- REQUIRED TRACTOR OIL 30lt
- Watertight stainless-steel tank with flowered sheet metal aisi 304

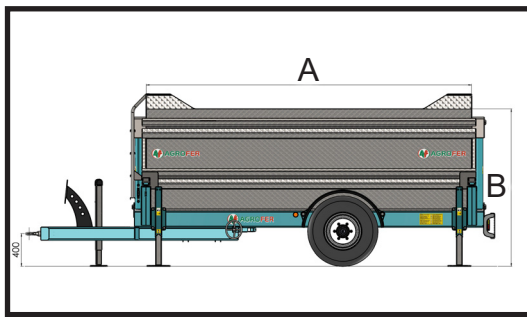
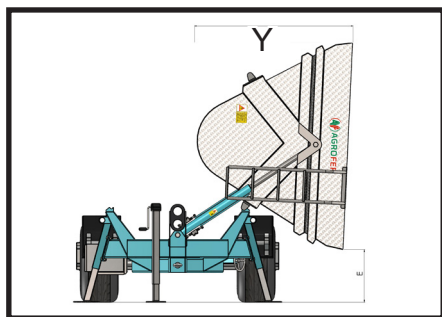
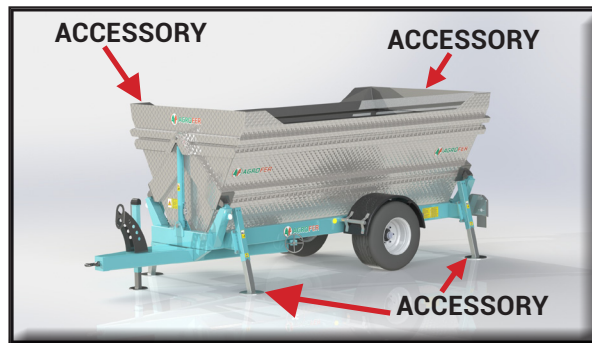

MOD.	A mm	B mm	C mm	D mm	Y mm		 Kg.	 m³	€
BL30	3000	1800	1800	1800	1200	10.075 15.3	1600	4	
BL40	4000	2200	1800	1800	1200	13/65 - 18	1750	6,5	

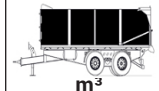
BRAKING SYSTEM COST FOR 6000Kg

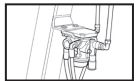
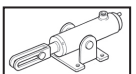
	PNEUMATIC	
	HYDRAULIC WITH PEDAL	