

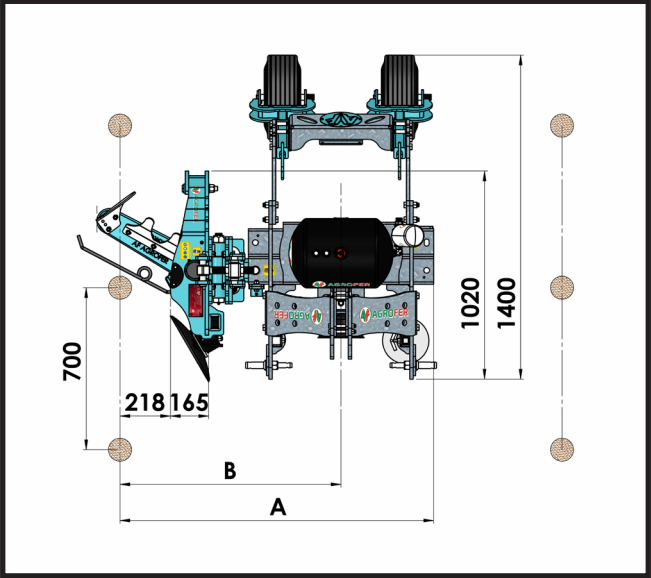

SYMPLEX DX

- Chassis carried to the 3 points of the lift
- Cut-tube profile chassis
- 2 adjustable rubber wheels
- Hydraulic system
- 550 mm blade tool
- Double-acting feeler cylinder

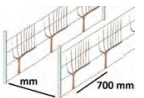

| MOD. mm | Kg | A min-max | B min-max |  HP |  min-max |  mm 700 mm |
|------------|--------------|--------------|--------------|---|--|--|
| PICCOLO | DA 360 A 580 | 1715 - 2215 | 1080 - 1580 | 30 | 50-200 | 1700 |
| MEDIO | | 1915 - 2415 | 1280 - 1780 | 30 | 50-200 | 2500 |
| GRANDE | | 2015 - 2515 | 1380 - 1880 | 30 | 50-200 | 3000 |

SYMPLEX DX EASY Electronic

- System operation with tractor oil
- FIXED TL 60 DX blade head, no inclination
- HYDRAULIC telescopic extension of the TL 60 DX blade head with tractor oil operation, 500mm extension
- 12 volt electric pushbutton panel on the tractor for emergency return of the TL 60 DX blade head
- Tractor with 2 pairs of double-acting hydraulic jacks
- LT 30 tractor

REAR OR FRONT

TO CONFIRM

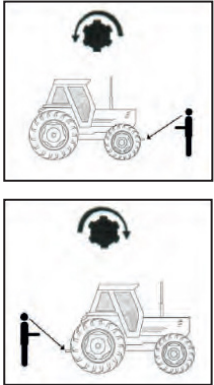

FRONT
OR
REAR

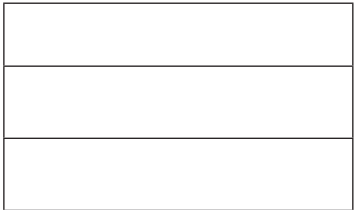
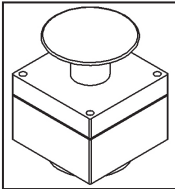

SYMPLEX DX ECO Electronic

REAR OR FRONT

- System operation with tractor oil
- HYDRAULIC oblique inclination of the TL 60 DX blade head + 15°-15° tractor oil operation
- HYDRAULIC telescopic extension of the TL 60 DX blade head with tractor oil operation, 500mm extension
- 12 volt ELECTRIC pushbutton panel on the tractor for emergency return of the TL 60 DX blade head
- Tractor with N3 pairs of double-acting hydraulic jacks
- LT 30 tractor

TO CONFIRM

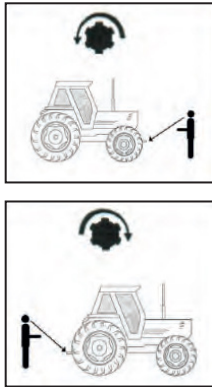

FRONT
OR
REAR

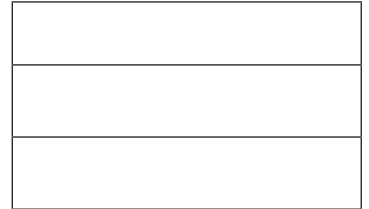
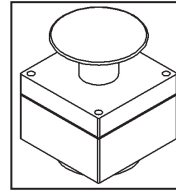

SYMPLEX DX TOP Electronic

REAR OR FRONT

- System operation with pump and oil tank
- HYDRAULIC oblique inclination of the TL 60 DX blade head + 15°-15° tractor oil operation
- HYDRAULIC telescopic extension of the TL 60 DX blade head with tractor oil operation, 500mm extension
- 12 volt ELECTRIC pushbutton panel on the tractor for emergency return of the TL 60 DX blade head
- Tractor with 2 pairs of double-acting hydraulic jacks
- Tractor PTO socket 540 or 1000
- Pump kit fixed to the frame (1 pump)
- Cardan shaft
- LT 30 tractor

TO CONFIRM

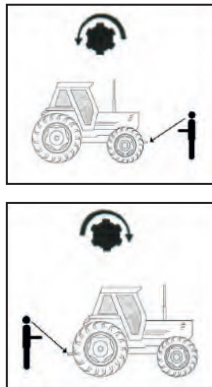

FRONT
OR
REAR

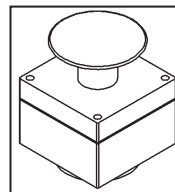

REVERSIBLE

KIT REVERSIBLE

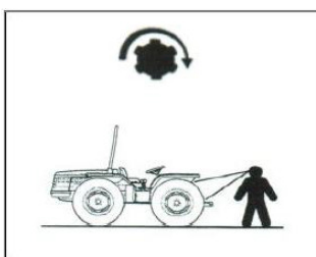

ONLY
MOD. TOP

