

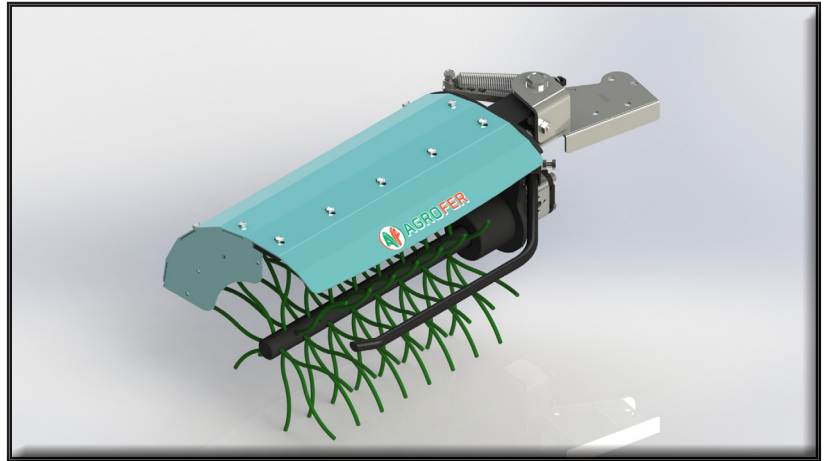





TIPPING MACHINE GREEN DX

- Tipping rotor
- Ø 400 mm - lenght 500 mm
- Wire fixing with appropriate bolt
- Covering carter
- Non-stop spring system
- Adjustable sensor rods for distance near the plant
- N° 3 hydraulic pipes length 200 mm
- Tractor oil operation
- N° 1 pair of double-acting hydraulic jacks

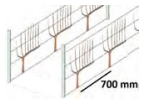
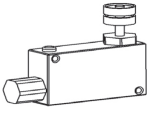

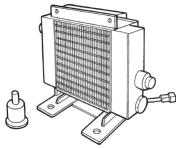

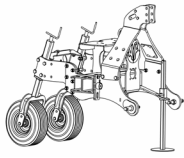
| | | | |
|---------------------------|-----------|---|---|
| MOD. | Kg |  |  |
| TIPPING MACHINE DX | 50 | HP 30 | 700 |

| IMAGE | CODE | DESCRIPTION | PRICE |
|---|----------|--|-------|
|  | SP001 DX | SPEED REGULATION VALVE | |
|  | SP002 DX | ELECTRIC PUSH BUTTON PAD WITH SPEED REGULATION VALVE | |
|  | SP003 DX | OIL COOLER MOD. DX | |
|  | SP004 DX | INDEPENDENT PLANT FROM TRACTOR COMPLETE WITH PUMP 14lt AND OIL TANK 25lt | |
|  | SP005 DX | REAR CHASSIS DX HYDRAULIC SLIDE DX N°2 ADJUSTABLE RUBBER WHEELS | |

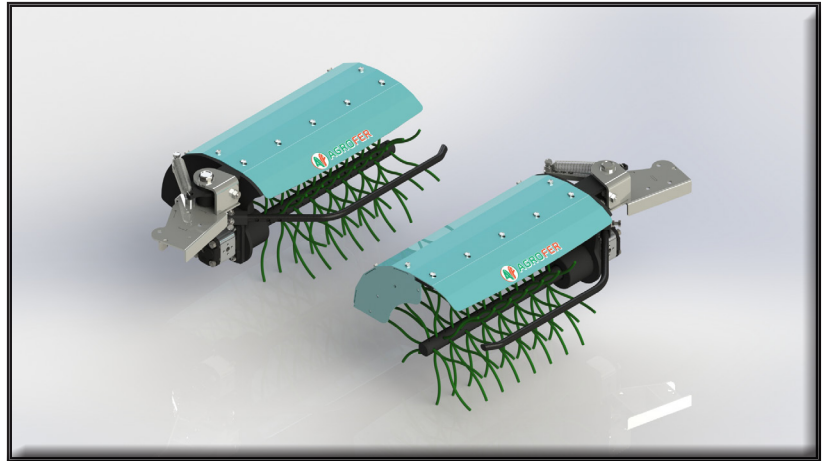

TIPPING MACHINE DX-SX GREEN

- Tipping rotors for right side – left side
- Ø 400 mm - lenght 500 mm
- Wire fixing with appropriate bolt
- Covering carter
- Non-stop spring system
- Adjustable sensor rods for distance near the plant
- N° 6 hydraulic pipes length 200 mm
- Tractor oil operation
- N° 2 pair of double-acting hydraulic jacks

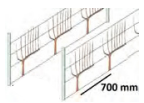

| | | | |
|------------------------------|-----------|---|---|
| MOD. | Kg |  |  |
| TIPPING MACHINE DX-SX | 100 | HP 30 | 700 |

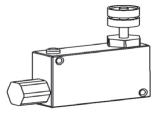
ACCESSORIES

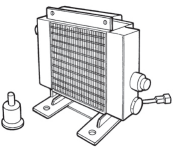
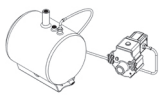
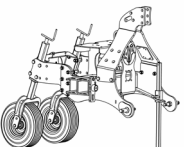
| IMAGE | CODE | DESCRIPTION | PRICE |
|---|----------------|--|-------|
|  | SP001 DX | SPEED REGULATION VALVE | |
|  | SP002 DX-SX | ELECTRIC PUSH BUTTON PAD WITH SPEED REGULATION VALVE | |
|  | SP003 DX-SX | OIL COOLER MOD. DX-SX | |
|  | SP004 DX-SX | INDEPENDENT PLANT FROM TRACTOR COMPLETE WITH PUMP 22+22 lt AND OIL TANK 50lt | |
|  | SP005 DX-SX | REAR CHASSIS DX-SX HYDRAULIC SLIDE DX-SX N°2 ADJUSTABLE RUBBER WHEELS | |