

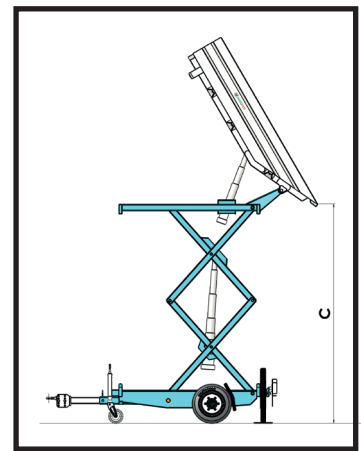

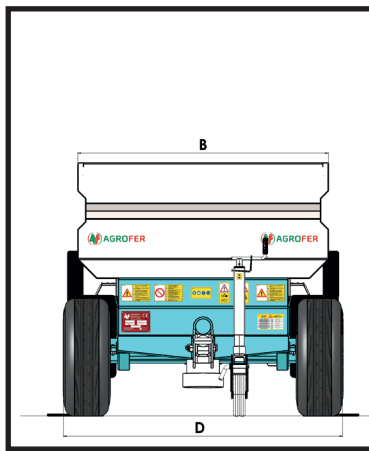

CARRO DDF INOX

- Carro per la raccolta e il trasporto dell'uva
- Vasca a tenuta stagna in acciaio inox con lamiera fiorettata AISI 304
- Timone fisso
- Assale rigido con freno meccanico
- Occhione E3
- Piedino d'appoggio mobile
- Struttura a forbice alzata idraulica con cilindro idraulico olio trattore
- Con scarico posteriore alzata vasca con cilindro idraulico olio trattore
- Kit fanali
- Trattore: n°2 coppie di prese idrauliche doppio effetto

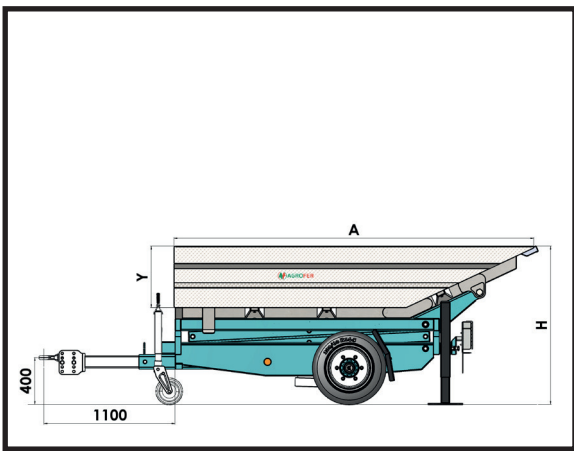

MOD.	A mm	B mm	C mm	D mm	Y mm	H mm		 Kg.	 M ³		
DDF 13	3000	1300	3500	1400	500	1300	10.075 15.3	1100	1.7		
DDF 15	3000	1500	3500	1600	500	1300	10.075 15.3	1200	2.5		
DDF 18	3500	1800	3300	1800	800	1300	340/55-16	1650	3.5		
DDF 18 S	4000	1800	3300	1800	500	1300	340/55-16	1850	3.0		
DDF 18 M	4000	1800	3300	1800	800	1500	340/55-16	2000	4.5		

COSTI SISTEMA FRENANTE PER OMOLOGAZIONE STRADALE 6000 Kg

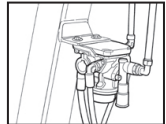
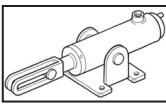
	PNEUMATICO	
	IDRAULICO A PEDALE	