

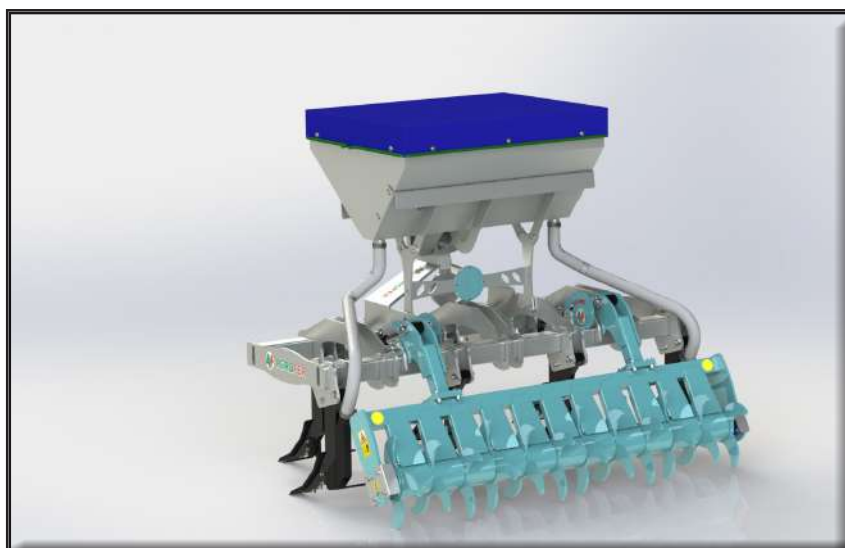

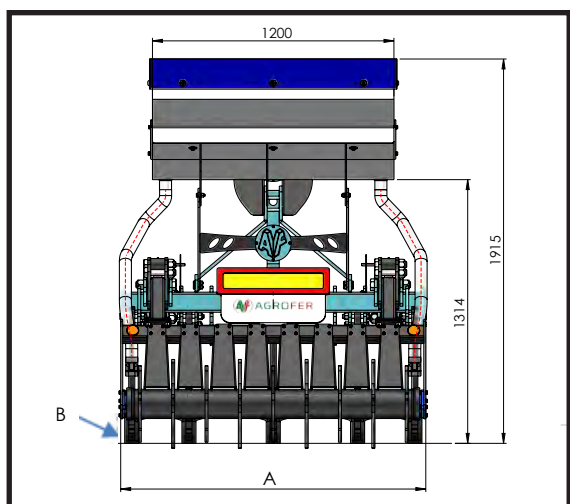

RIPUNTATORE DIS R.I. C.

- TELAIO IN TUBOLARE SEZIONATO 100x100x8
- Attacco ai tre punti del sollevatore
- Ancore fisse con bullone di sicurezza
- Rullo di profondità con regolazione idraulica
- Completo di vasca in acciaio inox con portata 450 lt. con coclea idraulica
- Apertura idraulica per dosaggio prodotto
- Regolatore manuale
- Trattore con 6 prese idrauliche a doppio effetto

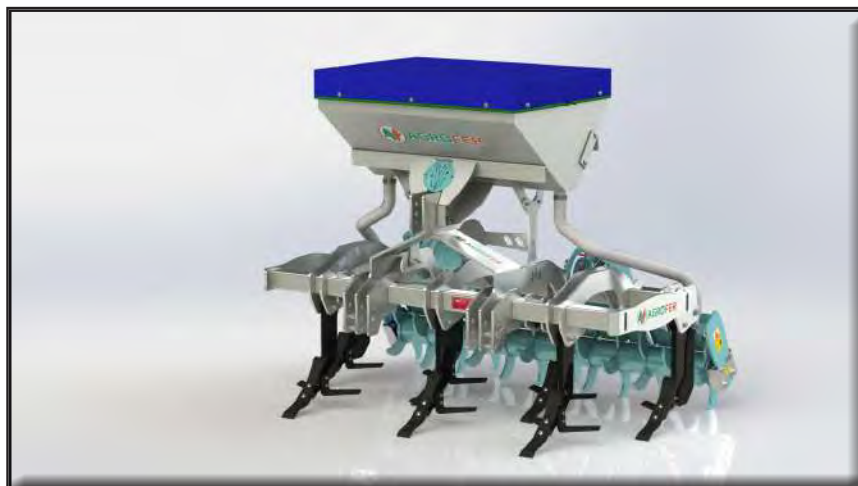
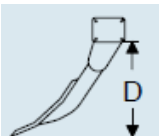

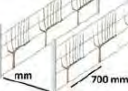
MOD.	A mm	B N°	 Altezza Ancore mm		 700 mm	Kg	 HP
DIS.RI.C 15	1500	5	550	500	1800	710	70
DIS.RI.C 18	1800	5	550	500	2000	760	70
DIS.RI.C 22	2200	7	550	500	2500	930	100

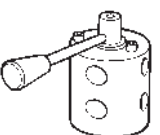
	DIS.RI.C.	DEVIATORE A 2 VIE Comanda: dosaggio di prodotto rullo di profondità		DIS.RI.C.
---	-----------	--	--	-----------