

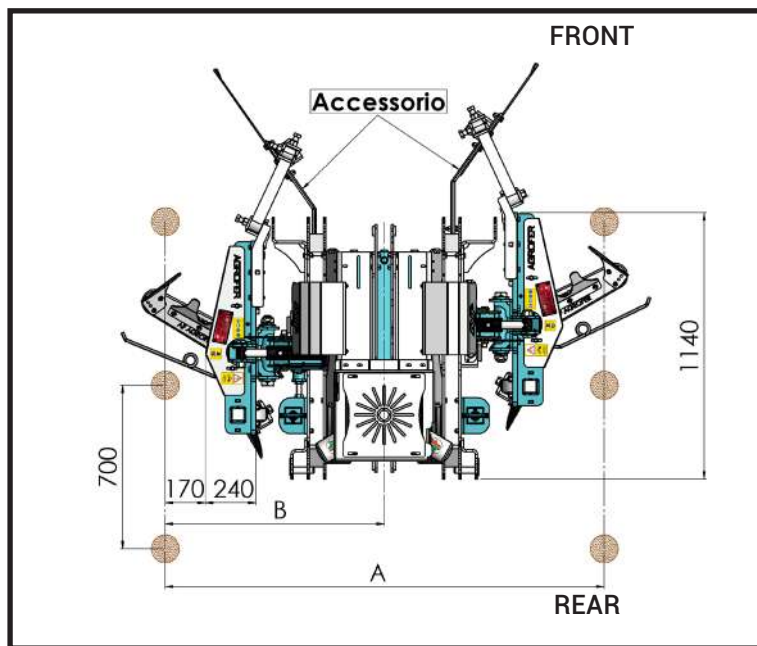

# BARING MACHINE COMBY DX - SX

• DOUBLE INTER-RROW MACHINE DX-SX WITH 3 POINTS

HITCH REVERSIBLE

- Cut-tube profile frame
- N° 2 adjustable supporting rubber wheels
- Hydraulic system
- 550 mm blade tool
- 12V electric button panel to control:
  1. Oblique hydraulic, independent inclination of right/left blade head on bumpy ground +15° - 15°
  2. Hydraulic right-left sides telescopic extension: 500 mm
  3. Singular emergency retraction of right or left tools
  4. Simultaneous emergency retraction of right and left tools

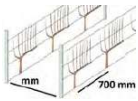

MOD. mm	Kg	A min-max	B min-max	 HP	 mm
PICCOLO	580	2030 - 3030	845 - 1345	60	1900
MEDIO	680	2500 - 3500	1080 - 1580	60	2400
GRANDE	750	2900 - 3900	1280 - 1780	70	2700
MAGNUM	790	3100 - 4100	1380 - 1880	70	3000

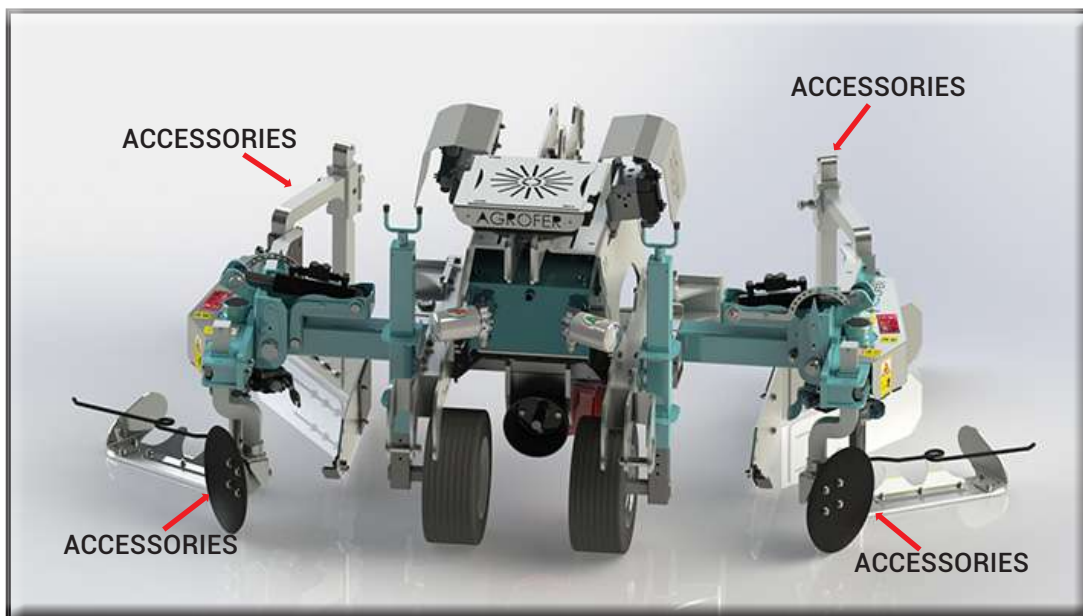

## COMBY DX-SX EASY *Electronic*

- System operation with tractor oil
- TRACTOR: with 1 pair of hydraulic double-effect jacks
- TRACTOR Lt. 50 /min

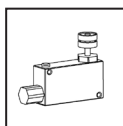

Mod. PICCOLO

Mod. MEDIO

Mod. GRANDE

Mod. MAGNUM

## COMBY DX-SX PLUS *Electronic*

- System operation with tractor oil
- TRACTOR: with 1 pair of hydraulic double-effect jacks
- OIL COOLER
- TRACTOR Lt. 50 /min

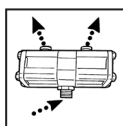

Mod. PICCOLO

Mod. MEDIO

Mod. GRANDE

Mod. MAGNUM

### KIT VARIO ON DEMAND:

No PTO; kit for rotation of hydraulic tools for tractors hydraulic controls variable pumps

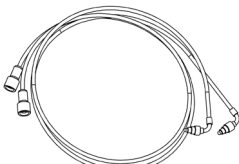

## ON DEMAND

IMAGE	CODE	DESCRIPTION	PRICE
	EX 001	HYDRAULIC PIPES for front application without PTO length 5200 mm N° 1 da 3/4 N° 1 da 1/2	

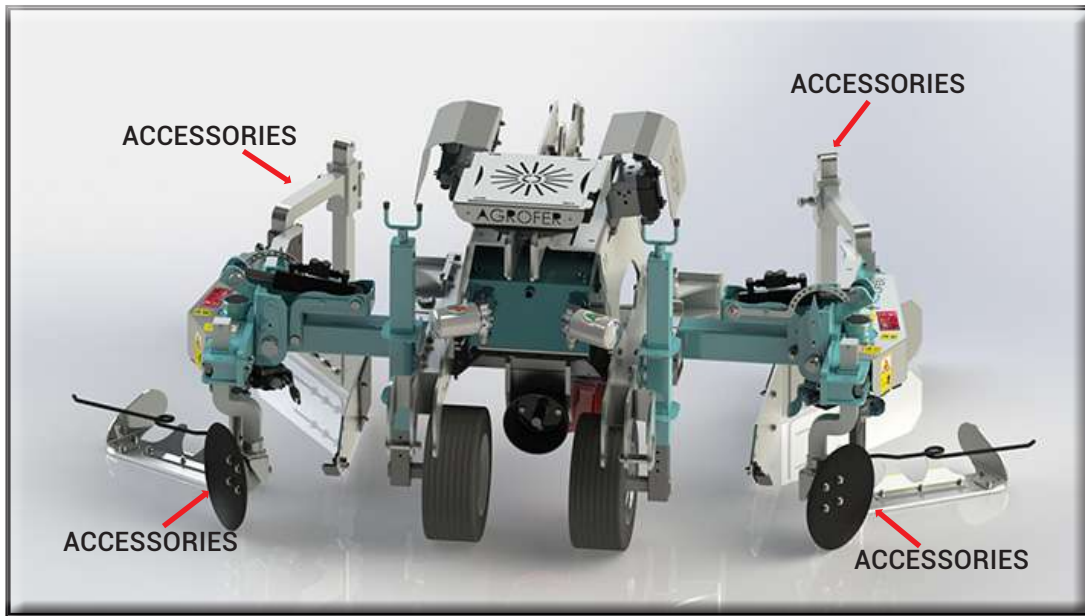

### COMBY DX-SX TOP *Electronic*

- System operation with oil tank and pump
- TRACTOR: PTO 540 or 1000
- Kit pump fixed to the chassis (2 pumps)
- Cardan Shaft



Mod. PICCOLO
Mod. MEDIO
Mod. GRANDE
Mod. MAGNUM

### COMBY DX-SX PREMIUM *Electronic*

- System operation with oil tank and pump
- ON-OFF button for hydraulic tools
- OIL COOLER
- KIT FOR HYDRAULIC TOOLS
- TRACTOR: PTO 540 or 1000
- Kit pump fixed to the chassis (3 pumps)
- Cardan Shaft



### KIT FOR HYDRAULIC TOOLS

Mod. PICCOLO
Mod. MEDIO
Mod. GRANDE
Mod. MAGNUM

## COMBY DX/SX TOP E PREMIUM STANDARD

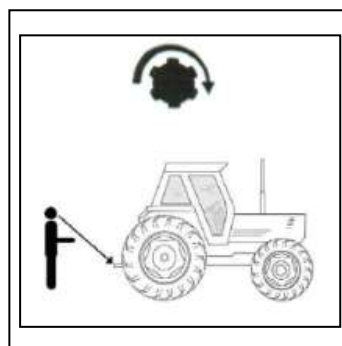
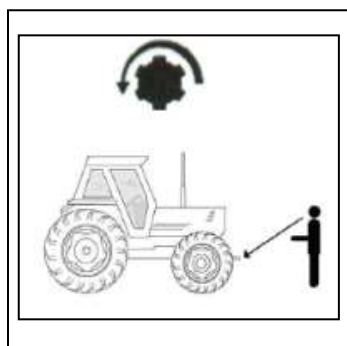

### NO FRONT PTO

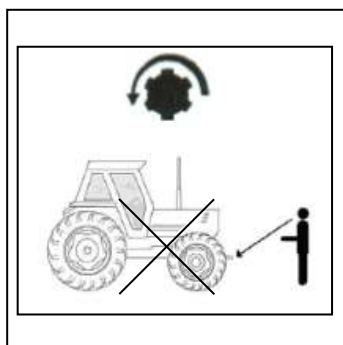

### ONLY FOR MOD. TOP-PREMIUM

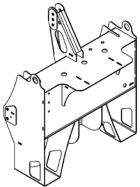
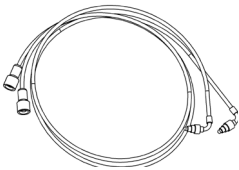
IMAGE	CODE	DESCRIPTION	PRICE	MACHINE
	EX 003	3 POINTS CHASSIS without pump, without oil		COMBY TOP COMBY PREMIUM
	CO 001	HYDRAULIC PIPES length 5200 mm N° 2 da 3/4 N° 2 da 1/2		COMBY TOP
	CO 002	HYDRAULIC PIPES length 5200 mm N° 1 da 3/4 N° 3 da 1/2		COMBY PREMIUM

### REVERSIBLE

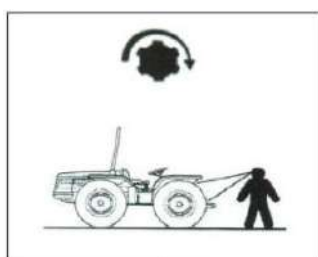

### KIT REVERSIBLE

